

Co-Wound Voltage Sensor R&D for TPX Magnets

Michael R. Chaplin, Nicolai N. Martovetsky, Jon P. Zbasnik, J. Richard Hale,
Joel H. Schultz, Shahin Pourrahimi, Stephen Smith, Pei-Wen Wang

This paper was prepared for submittal to the
Proceedings of the 16th IEEE/NPSS Symposium on Fusion Engineering
Champaign, Illinois
September 30 - October 5, 1995

September 29, 1995

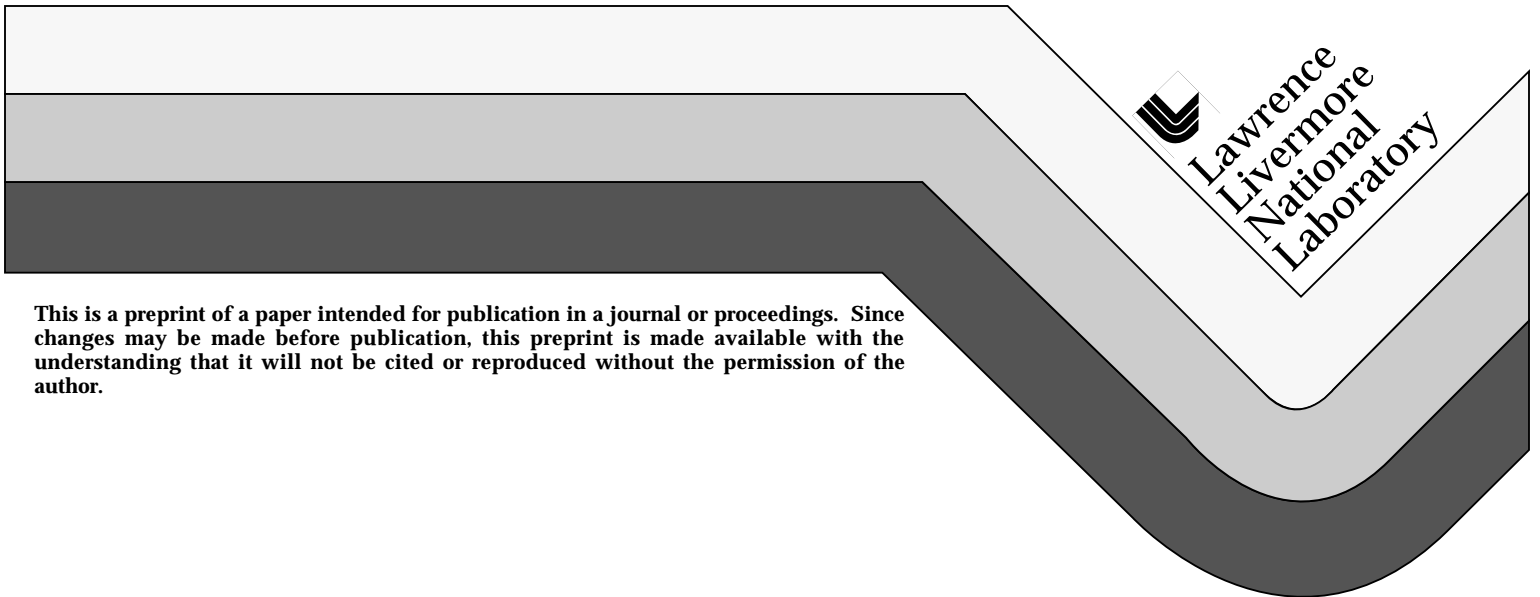

This is a preprint of a paper intended for publication in a journal or proceedings. Since changes may be made before publication, this preprint is made available with the understanding that it will not be cited or reproduced without the permission of the author.

DISCLAIMER

This document was prepared as an account of work sponsored by an agency of the United States Government. Neither the United States Government nor the University of California nor any of their employees, makes any warranty, express or implied, or assumes any legal liability or responsibility for the accuracy, completeness, or usefulness of any information, apparatus, product, or process disclosed, or represents that its use would not infringe privately owned rights. Reference herein to any specific commercial product, process, or service by trade name, trademark, manufacturer, or otherwise, does not necessarily constitute or imply its endorsement, recommendation, or favoring by the United States Government or the University of California. The views and opinions of authors expressed herein do not necessarily state or reflect those of the United States Government or the University of California, and shall not be used for advertising or product endorsement purposes.

Co-Wound Voltage Sensor R&D for TPX Magnets*

Michael R. Chaplin, Nicolai N. Martovetsky, Jon P. Zbasnik
Lawrence Livermore National Laboratory, Livermore, CA, 94550

J. Richard Hale, Joel H. Schultz, Shahin Pourrahimi, Stephen Smith, Pei-Wen Wang
Massachusetts Institute of Technology - Plasma Fusion Center, Cambridge, MA, 02139

ABSTRACT

The Tokamak Physics Experiment (TPX) will be the first tokamak to use superconducting cable-in-conduit-conductors (CICC) in all Poloidal Field (PF) & Toroidal Field (TF) magnets. Conventional quench detection, the measurement of small resistive normal-zone voltages (<1 V) in the magnets will be complicated by the presence of large inductive voltages (>4 kV). In the quench detection design for TPX, we have considered several different locations for internal co-wound voltage sensors in the cable cross-section as the primary mechanism to cancel this inductive noise. The Noise Rejection Experiment (NRE) at LLNL and the Noise Injection Experiment (NIE) at MIT have been designed to evaluate which internal locations will produce the best inductive-noise cancellation, and provide us with experimental data to calibrate analysis codes. The details of the experiments and resulting data are presented.

INTRODUCTION

The detection of a resistive normal-zone, or quench, in superconducting magnets has traditionally been accomplished by measuring the voltage across the resistance of the normal zone caused by the magnet's current. Even in DC magnets, though, the inductive voltages from di/dt can be several orders of magnitude greater than the resistive voltage component. To make this measurement possible, the inductive voltage must be reduced, or canceled, to a level less than the resistive component. Several techniques have been applied over the years to accomplish this; the most popular being the balanced-bridge scheme shown on the left in Fig. 1. During charging of the magnet, the resistor is adjusted to null the differential voltage, V_1 . When the primary inductive signals are the self di/dt of the magnet or of concentric sets of magnets, the balanced bridge is effective at reducing the inductive-signal component by a factor of 1000 or more.

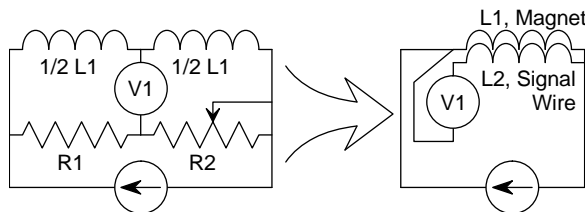

Figure 1: Balanced-Bridge & Co-Wound Sensor Quench Detection

In the magnet systems of a tokamak though, there are several sources of inductive noise that the balanced bridge would be ineffective at reducing sufficiently. Because of the complex field requirements of a tokamak, its magnets are exposed to

time-varying, non-symmetrical transverse and parallel fields that a static balanced bridge can not compensate for. Ideally, what is needed is a second inductive element with the same dimensions and area of the magnet's winding pack, and the same twist pitches of the internal strands. The second inductor would then receive the exact same inductive signals from all sources that the magnet is exposed to. For the design of the Tokamak Physics Experiment (TPX) magnets, we investigated the use of co-wound voltage sensors that would be used as shown on the right in Fig. 1.

QUENCH-VOLTAGE DETECTION FOR TPX

Magnet Parameters

The TPX magnets will endure large dB/dt associated with the plasma initiation and any subsequent disruptions. Analysis [3,4] indicates that PFs will experience a maximum of 12.8 T/s and the TFs 22.3 T/s from a fast plasma disruption. With the 16 TF magnets divided into two series sets during a rapid discharge, each is exposed to just less than 1 kV terminal-to-terminal; however in a single null operating mode, the PF magnets will be exposed to as much as 4 kV terminal-to-terminal during the plasma initiation. Quench analyses [5] indicate that to discharge the magnets quickly enough to prevent the hot-spot temperature from rising above 150 K, we must detect a normal zone voltage of 0.4-0.8 V in a maximum of one second. Reference [6] states that a 10:1 signal-to-noise ratio for the quench detection sensors must be attained to show feasibility of this sensing technique. With the numbers shown above, we see that the inductive noise signals (up to 4 kV) must be reduced to below ($0.4 \text{ V}/10 = 0.04 \text{ V}$) by the end the one-second detection window.

CICC & Co-Wound Voltage Sensors

The CICC of the TPX PF1-5 magnets has 360, 0.78-mm Nb_3Sn strands cabled as shown in Table I. For TPX, an analysis [2] of several conductor locations for the co-wound voltage sensors were made, and the following locations were considered for testing;

- I. Twisted in the first stage of cabling (triplex) and therefore twisted with the same cabling pattern as all other strands,
- II. Placed outside the cable (but inside the conduit) in "valleys" of the last stage cabling and therefore twisted with the last stage cable,
- III. Placed in the center of the last stage (3rd) subcable and therefore has the same twist pitch as the last cabling stage,

* This work was performed under the auspices of the U.S. Department of Energy by the Lawrence Livermore National Laboratory under contract No. W-7405-Eng-48 and the Princeton Plasma Physics Laboratory under contract number DE-AC02-76-CH03073.

- IV. Placed in the geometric center of the CICC, and
- V. Placed outside the sheath, but not twisted around the conductor.

Table I: TPX PF Magnet CICC Parameters

Cable Stage	Cable Pattern	Twist Pitch
1	3 strands	50 mm
2	stage 1 x 4	100 mm
3	stage 2 x 5	200 mm
4	stage 3 x 6	400 mm

Sensor location V is the only option of applying a co-wound sensor during magnet insulation; after the heat-treatment phase for the conductor. However, it was ruled out early in our evaluation process because of the concern about electrical shorts from wires in the insulation pack.

Location IV is the easiest to manufacture or cable, but should be the least effective at picking up the same inductive voltages of the strands as it has none of the 4 stages of twist pitch associated with the strands.

Location III would be relatively simple to manufacture. With it having the same twist pitch as the last subcable, it should pickup most of the inductive voltages seen by the strands.

Location II is similar to IV as far as manufacturing; but may actually pickup more inductive voltage than the strands due to its loops having a larger area than the strands.

Location I would be difficult to manufacture if the other two strands in the triplex are Nb₃Sn. There is also speculation that this may cause problems for the superconducting strands of the triplex not being able to transfer current to both of its triplex partners. However, location I should have the best match to the strands for inductive voltage pickup since its path through all cable stages and twist pitches is the same. To eliminate possible conductor performance issues, one (or more) of the 1st-stage triplexes should be made up of three sensor wires.

R&D EXPERIMENTS

LLNL Noise-Rejection Experiment

The LLNL Noise-Rejection Experiment (NRE) [7,8] tested the noise-rejection capabilities of co-wound sensors (or wires) at each of the locations noted above. The wires will be used as voltage taps in a copper test coil with a full-size conductor (without a metal conduit) and the same initial cabling pattern as the TPX PF conductor. The dB/dt testing conditions included external transverse, parallel, and self (di/dt) fields. Because the noise-coupling issues of signal wires located inside a cable are not dependent on temperature or resistivity, this experiment design with a room-temperature copper conductor should provide good test results for evaluating the effectiveness of the different signal-wire locations. The cable will use 360 0.78 mm copper stands, and is shown in Fig. 2.

The Noise-Rejection Test Coil (NRTC) is a layer wound solenoid with 36 turns. A Parallel-Field Coil (PFC) was wound as a toroid around the NRTC. This assembly was

then placed in the bore of a pair of existing Transverse-Field Coils (TFCs) for testing, as shown in Fig. 3.

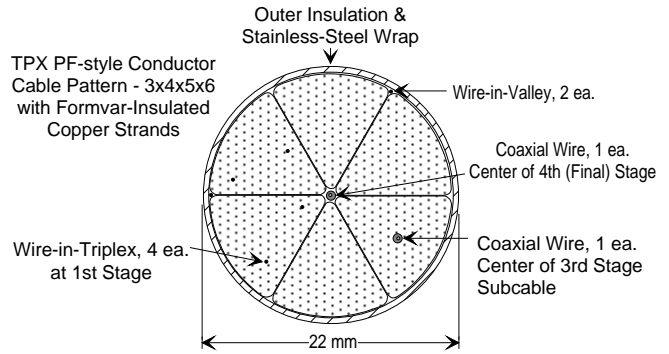

Figure 2: Cable Configuration for the NRTC

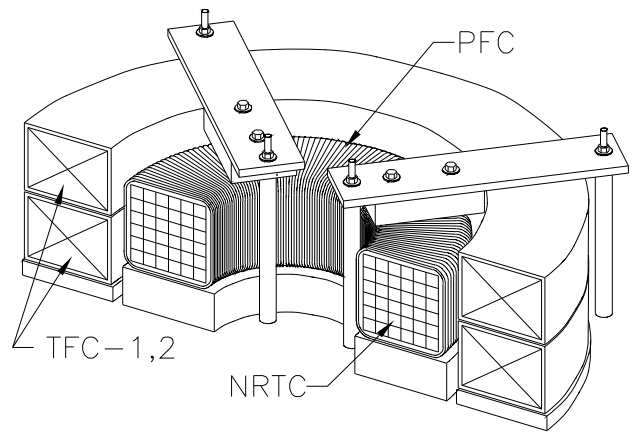

Figure 3: Coil Configuration for the NRE

The current source for this experiment was the Japan Atomic Energy Research Institute (JAERI) Inductive-Heating Power Supply on loan to the FENIX Test Facility at LLNL. This power supply consists of a 2000μF capacitor bank with thyristor switches to "ring" the NRE coils individually during the experiment. The capacitor bank can be charged up to 1500 V, and the thyristors can deliver current pulses up to 1000 A. The JAERI power supply was re-configured as show in Fig. 4 to provide the desired current waveforms and frequencies.

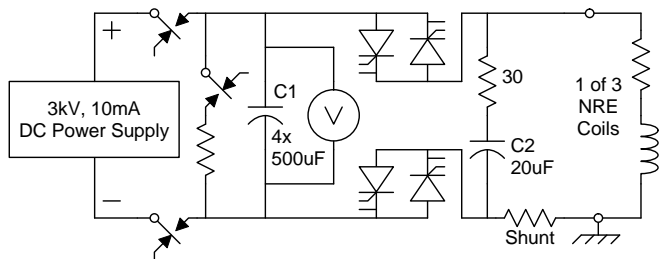

Figure 4: JAERI Power Supply for the NRE

All voltage sensors are terminated with the copper strands into a clamped, copper block at terminal A of the NRTC. At the other end the copper strands are terminated into a similar copper block (terminal B), but with the voltage sensor wires extracted just before the block. These sensor wires are then

paired with wires from the adjacent copper block and routed to the data acquisition system. In addition to these co-wound sensors, 2 pairs of conventional voltages taps are paired from the copper blocks to measure the full inductive voltage that will appear across the NRTC as shown in Fig. 5. The NRTC was wound in early June, 1995; and the experiment was completed in July, 1995.

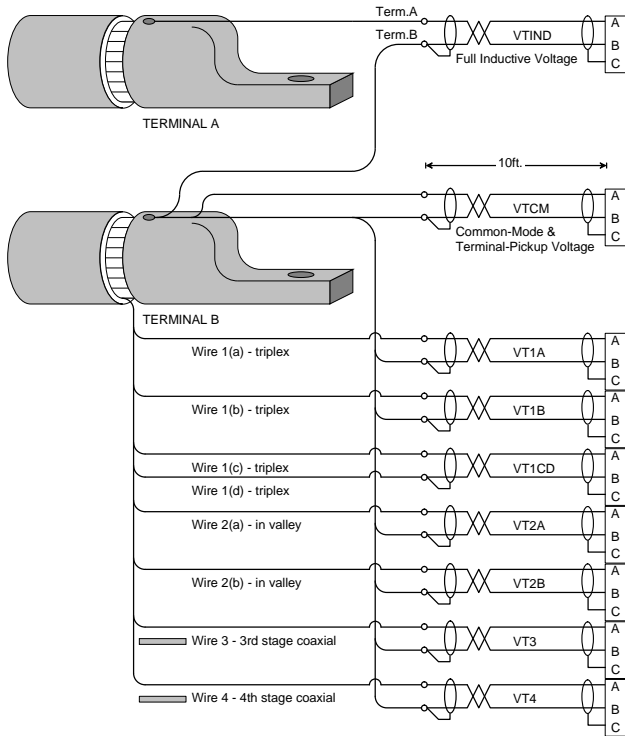

Figure 5: Sensor Wiring Diagram for the NRTC

NRE Results & Analysis

The resulting test conditions and data summary for the NRE are listed in Table II. The voltage taps (VTn) are numbered to indicate their location in the NRTC cable as stated above. V_{NRTC} is the induced voltage across the NRTC as measured at its terminals. Rejection Factors are calculated as (V_{NRTC}/VTn) . For the self-field test mode, the IR voltage drop in the NRTC cable had to be subtracted from the raw signals to show the resultant inductive voltage term only.

As can be seen in the data below, the sensor in location IV (VT4) performs the worst with the sensor in location I (VT1) performing the best. Generally, VT3 was better than VT2; except in the parallel-field test where the larger VT2 radius makes a slight difference. Typical raw data from the 2-coil transverse test mode are shown in the 3 graphs of Figures. 6-8. In analyzing the NRE data, it was discovered that the multiple sensors at some locations were producing largely varying data. During a post experiment checkout, it was discovered that the sensors with the worst or largest signals were shorted to some of the cable strands by multiple shorts via the stainless-steel tape. Evidently, the inner edge on the tape was turning down and after the NRTC was wound and assembled, the tape cut through the formvar insulation. Although this caused signals larger than expected for some sensors, the amplitudes were surprisingly small.

Table II: NRE Results Summary

NRE Test Mode	Parameter	Peak Signal	Rejection Factor
1-Coil Transverse Field	dB/dt_{NRTC}	24 T/s	
	V_{NRTC}	89 V	
	VT1	2.6 mV	34,000
	VT2	8.9 mV	10,000
	VT3	3.9 mV	22,800
2-Coil Transverse Field	dB/dt_{NRTC}	21 T/s	
	V_{NRTC}	84 V	
	VT1	1.4 mV	59,600
	VT2	11.2 mV	7,500
	VT3	4.5 mV	18,500
Parallel Field	dB/dt_{NRTC}	49 T/s	
	V_{NRTC}	2.8 V	
	VT1	22.6 mV	125
	VT2	412 mV	6.8
	VT3	482 mV	5.9
Self Field (di/dt)	dB/dt_{NRTC}	165 T/s	
	V_{NRTC}	354 V	
	VT1	70 mV	5,060
	VT2	450 mV	790
	VT3	400 mV	890
	VT4	1.5 V	235

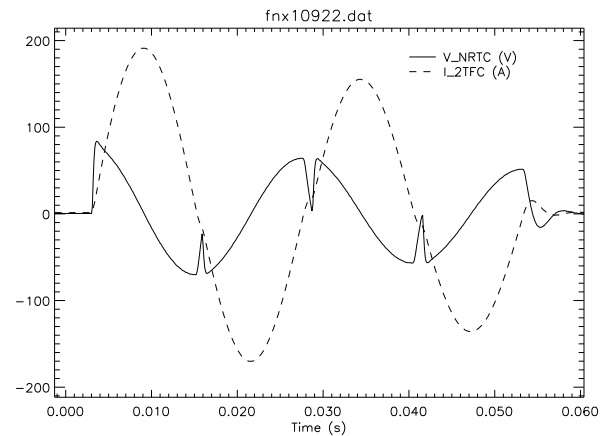

Figure 6: 2-Coil Transverse-Field NRE Data

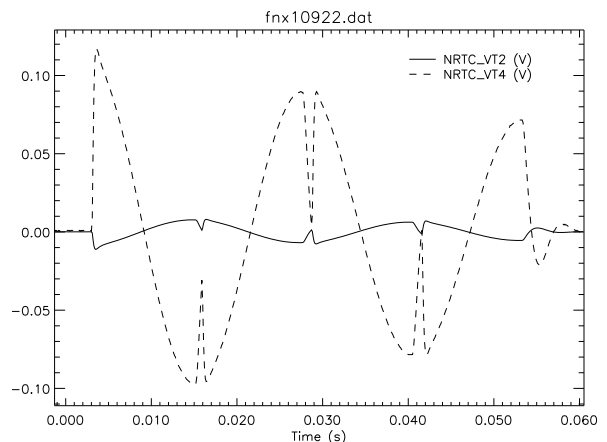

Figure 7: 2-Coil Transverse-Field NRE Data

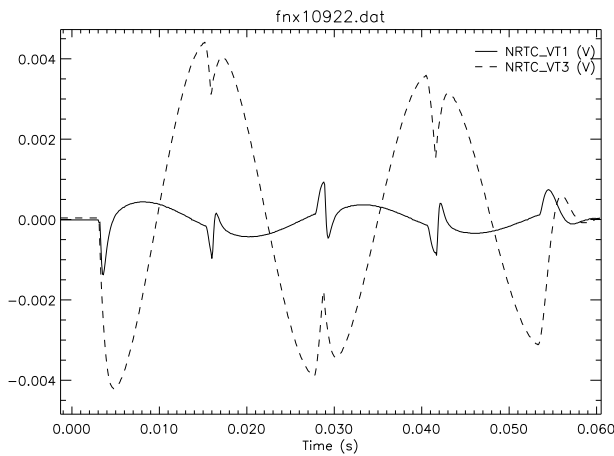

Figure 8: 2-Coil Transverse-Field NRE Data

MIT Noise-Injection Experiment

The Noise-Injection Experiment [9] was performed at the MIT magnet lab using 300 NbTi strands in a 3x5x5x4 cable pattern without a conduit. The NIE solenoid was wound with 6 m of this conductor and included voltage sensors in locations II, III, and IV as noted above. See Fig. 9 for the sensor locations and internal terminations. The sensor types are noted as Cu (copper) and CuNi (copper-nickel). Sensors C, D, G, J are internally terminated to test the segmentation scheme [10] considered for TPX. Transverse and self-field tests were performed. Preliminary transverse-test data is shown in Fig. 10.

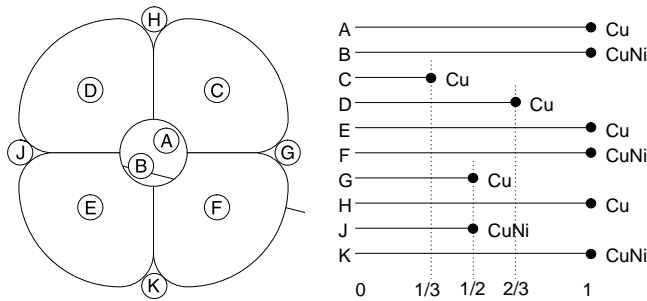

Figure 9: NIE Cable & Sensors

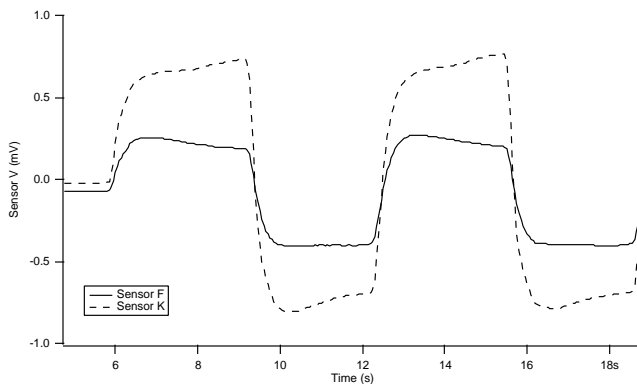

Figure 10: Preliminary NIE Transverse Data

The NIE coil was powered by a 5-kA power supply for the self-field tests. The transverse-field source was the 10A Bitter magnet. Data was collected and quickly looked at; however, a thorough analysis of the data and a final report have not yet been completed.

SUMMARY

Internal co-wound voltage sensors have been proposed and tested as part of the quench detection R&D program for TPX. The NRE & NIE experiments have verified the ability of these sensors to reduce the inductive noise to an acceptable level from all magnetic sources that the TPX magnets will be exposed to. Before either of these experiments were performed; the initial sensor location of choice was III, the center of the last stage subcable. Where it has an adequate rejection capacity for transverse fields, the performance of location I (in the triplex) is far superior for the parallel and self-fields. With the impending demise of the TPX project, ITER should seriously consider further development and inclusion of these sensors for the ITER Model Coils.

ACKNOWLEDGMENT

The authors would like to thank Jeff Moller, Mark Fowler, Andy Hinz, and Nate Liggins at LLNL for their contributions to the construction and setup of the experiment; JAERI for allowing LLNL to use their power supply to perform the NRE; and the MIT magnet lab staff for their assistance on the NIE.

REFERENCES

- [1] G Deis, et. al., "TPX superconducting tokamak magnet system 1995 design and status overview," 16th IEEE/NPSS Symposium on Fusion Engineering, Champaign, IL, Sept, 30, 1995, in press.
- [2] N.N. Martovetsky, M.R. Chaplin, "Normal-zone detection in tokamak superconducting magnets with co-wound voltage sensors", 14th Intl. Conf. on Magnet Tech., Tampere, Finland, June 11-16, 1995, in press.
- [3] P.W. Wang, "12 V startup with a maximum field null at the breakdown for TPX," TPX Doc.# 14-940627-MIT-PWang-01, PPPL, June, 1994.
- [4] A.L. Radovinsky, "Max. field & time derivatives in the TPX TF coils during plasma startup & plasma disruption, an update," TPX Doc.# 13-940725-MIT-ARadovinsky-01, PPPL, July, 1994.
- [5] J.H. Schultz, et. al., "Feasibility of the TPX voltage sensor quench detection system," TPX Memo # 1314-950818-MIT-JSchultz-01, PPPL, August 18, 1995.
- [6] I. Katz, et. al., "TPX structural & cryogenic design criteria," TPX Doc. # 94-950606-PPPL-IZatz-02, PPPL, June 6, 1995.
- [7] M.R. Chaplin, "Noise-Rejection Experiment for TPX Quench Detection R&D, rev. 1," TPX Doc.# 13-941110-LLNL-MChaplin-01, PPPL, November, 1994.
- [8] M.R. Chaplin, "Results from the LLNL Noise-Rejection Experiment," TPX Memo # 1314-950808-LLNL-MChaplin-01, PPPL, August 18, 1995.
- [9] J.R. Hale, "NIE Superconducting Sample: proposed configuration," TPX Memo # 1314-950504-MIT-JRHale-01, PPPL, June 4, 1995.
- [10] M.R. Chaplin, et. al., "Local I&C for the TPX PF & TF Magnets," 16th IEEE/NPSS Symposium on Fusion Engineering, Champaign, IL, Sept, 30, 1995, in press.

Technical Information Department • Lawrence Livermore National Laboratory
University of California • Livermore, California 94551

